

DURASTONE

150 HIGGINSON AVENUE - LINCOLN, RI 02865 - Phone (401) 723-7100 - Fax (401) 723-6866

DROP INLET

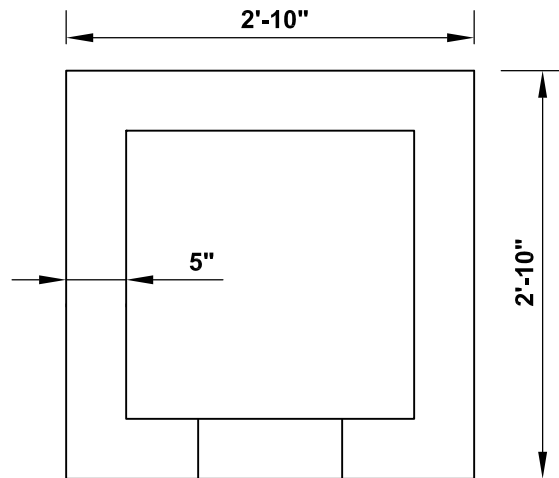

PLAN

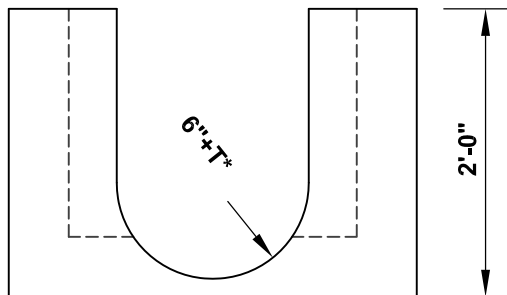

ELEVATION

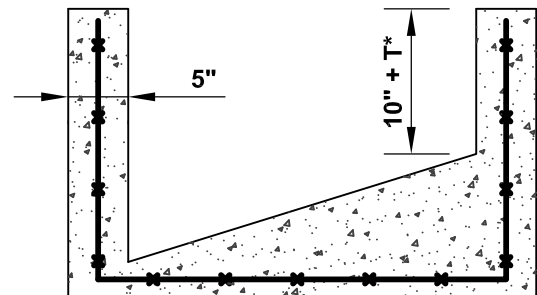

SECTION

* TW = WALL THICKNESS OF 12" RCP

APPROX. WEIGHT: 1,300 LB

STANDARD SPECIFICATIONS

1. MINIMUM REINFORCEMENT 6x6-W6xW6
2. MINIMUM CONCRETE COVER OF 2"
3. 5,000 PSI - ZERO SLUMP PORTLAND CEMENT CONCRETE MIX.
4. CONFORMS TO RI STANDARD 4.5.0

NPCA
CERTIFIED PLANT

DURASTONE

150 HIGGINSON AVENUE - LINCOLN, RI 02865 - Phone (401) 723-7100 - Fax (401) 723-6866

DROP INLET LATERAL OUTLET

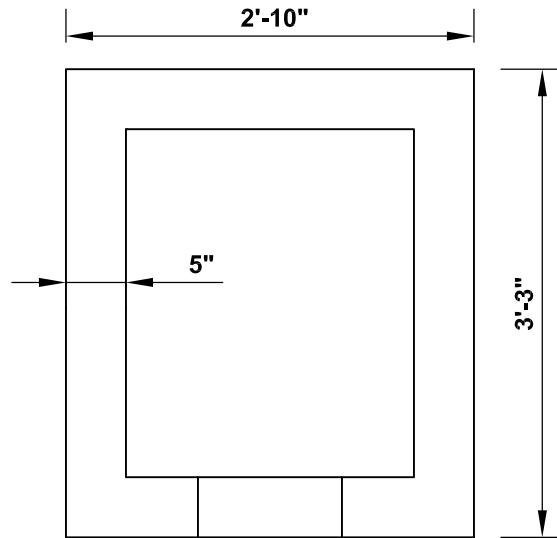

PLAN

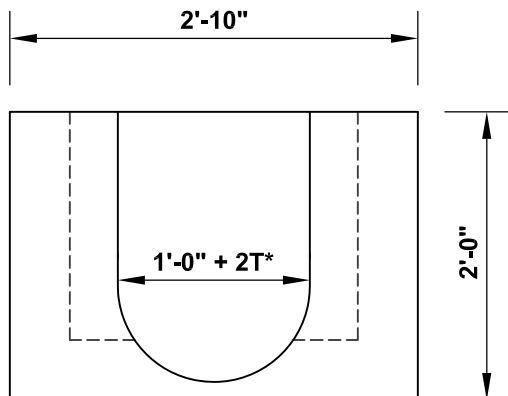

ELEVATION

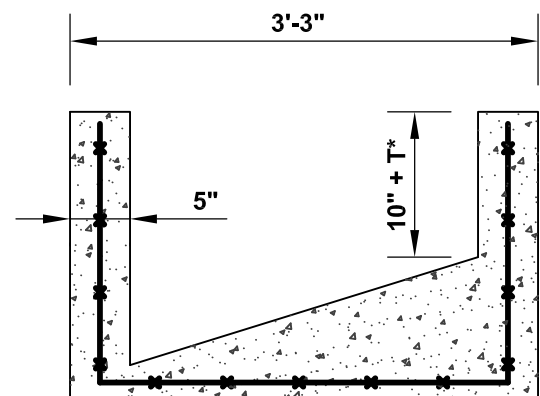

SECTION

*T = WALL THICKNESS OF 12" RCP

APPROX. WEIGHT: 1,600 LB

STANDARD SPECIFICATIONS

1. MINIMUM REINFORCEMENT 6x6-W6xW6
2. MINIMUM CONCRETE COVER OF 2"
3. 5,000 PSI - ZERO SLUMP PORTLAND CEMENT CONCRETE MIX.
4. CONFORMS TO RI STANDARD 4.5.1

NPCA
CERTIFIED PLANT

DURASTONE

150 HIGGINSON AVENUE - LINCOLN, RI 02865 - Phone (401) 723-7100 - Fax (401) 723-6866

DROP INLET LONGITUDINAL OUTLET

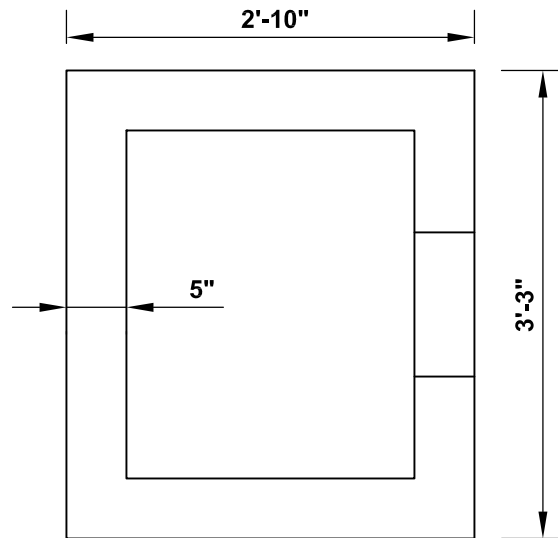

PLAN

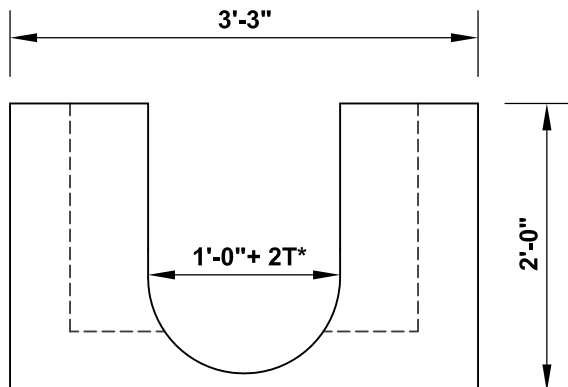

ELEVATION

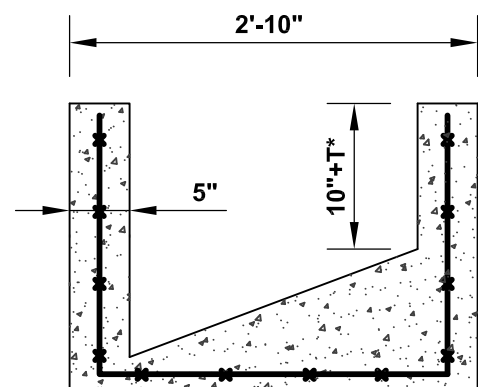

SECTION

* T = WALL THICKNESS OF 12" RCP

APPROX. WEIGHT: 1,600 LB

STANDARD SPECIFICATIONS

1. MINIMUM REINFORCEMENT 6x6-W6xW6
2. MINIMUM CONCRETE COVER OF 2"
3. 5,000 PSI - ZERO SLUMP PORTLAND CEMENT CONCRETE MIX.
4. CONFORMS TO RI STANDARD 4.5.2

NPCA
CERTIFIED PLANT

DURASTONE

150 HIGGINSON AVENUE - LINCOLN, RI 02865 - Phone (401) 723-7100 - Fax (401) 723-6866

4'-0" OR 6'-0" SQUARE MANHOLE OR CATCH BASIN

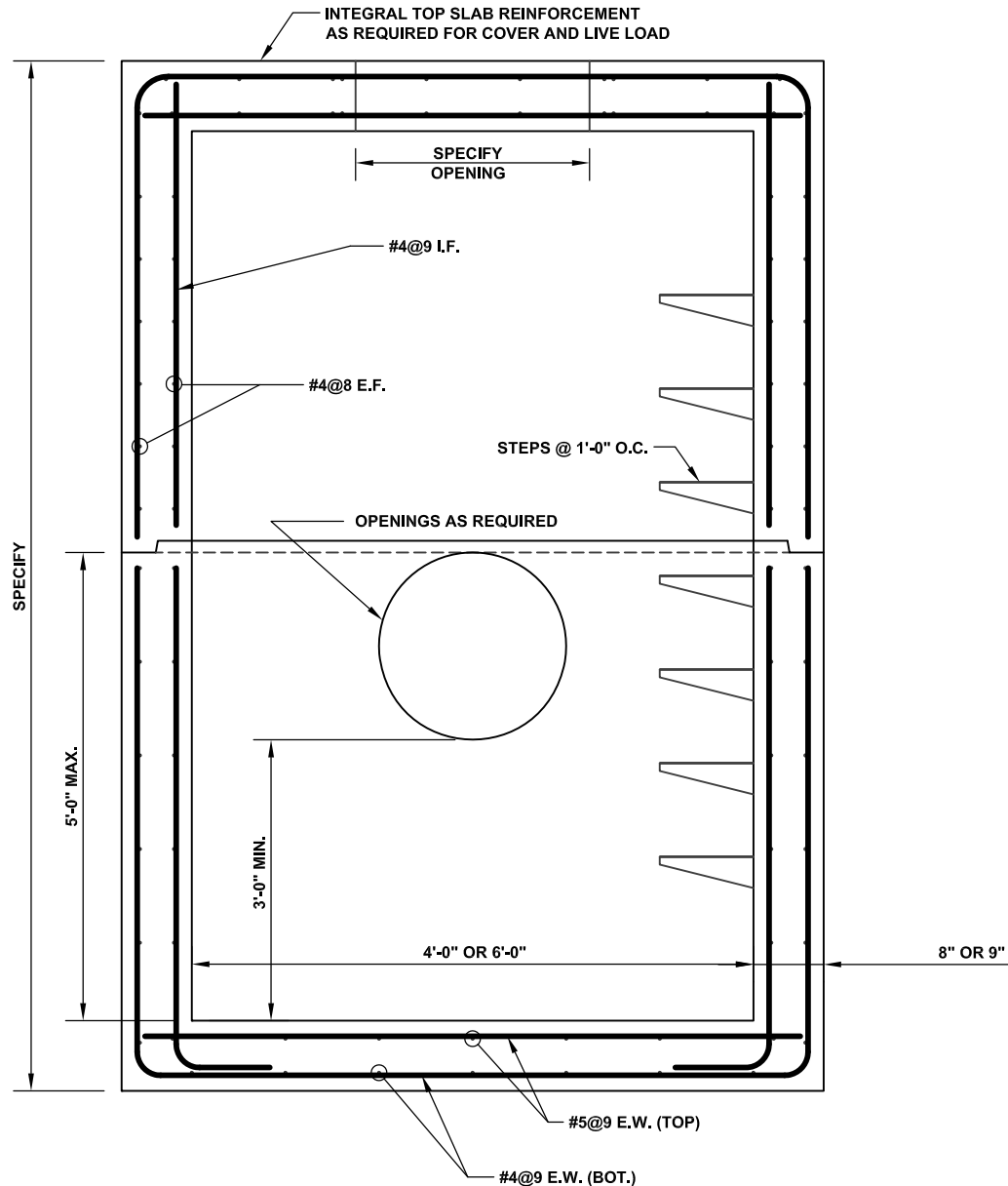

STANDARD SPECIFICATIONS

1. DESIGNED FOR HS20 LOADING.
2. OPENINGS AS SPECIFIED.
3. 5,000 PSI PORTLAND CEMENT CONCRETE MIX.
4. CONFORMS TO RI STANDARD 4.3.0

DURASTONE

150 HIGGINSON AVENUE - LINCOLN, RI 02865 - Phone (401) 723-7100 - Fax (401) 723-6866

PRECAST CONCRETE SUMP FOR CATCH BASINS

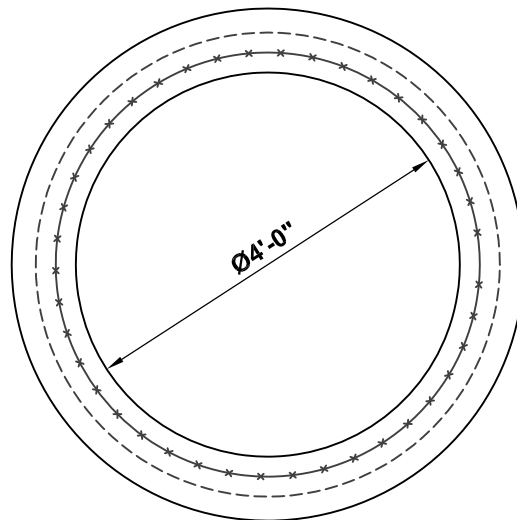

PLAN

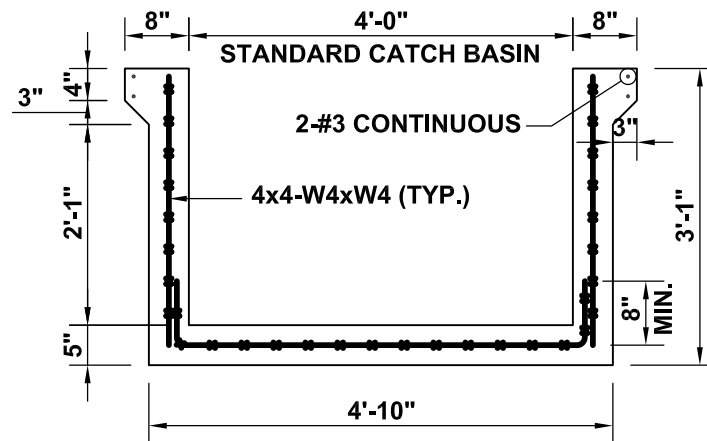

SECTION

STANDARD SPECIFICATIONS

1. SMOOTH FORM FINISH.
2. 4,000 PSI PORTLAND CEMENT CONCRETE MIX.
3. CONFORMS TO RI STANDARD 5.1.0