

DURASTONE

4'x4' PUMP CHAMBER

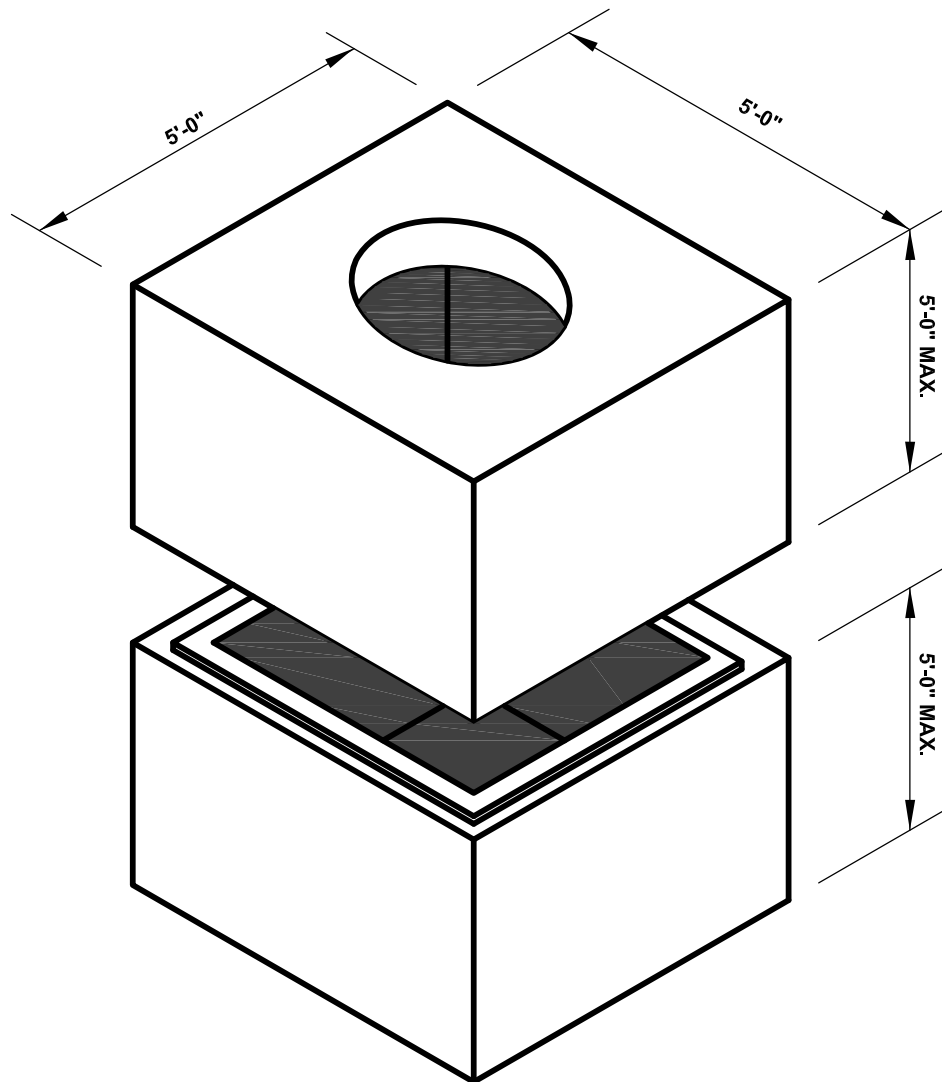

**APPROX. WEIGHT: 15,400 LB
AT MAX. HEIGHT W/O RISER**

INTERMEDIATE RISER SEGMENTS MAY BE
SPECIFIED TO PROVIDE ADDITIONAL DEPTH

150 HIGGINSON AVENUE - LINCOLN, RI 02865 - Phone (401) 723-7100 - Fax (401) 723-6866

NPCA
CERTIFIED PLANT

DURASTONE

150 HIGGINSON AVENUE - LINCOLN, RI 02865 - Phone (401) 723-7100 - Fax (401) 723-6866

4'x4' PUMP CHAMBER

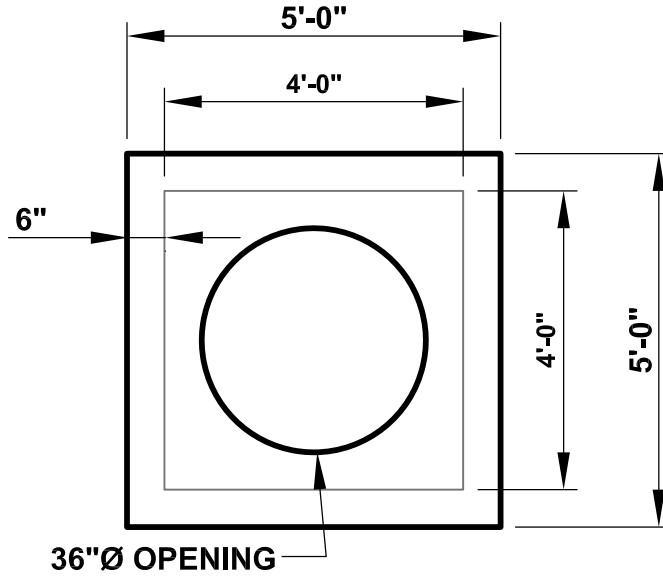

36"Ø OPENING

PLAN

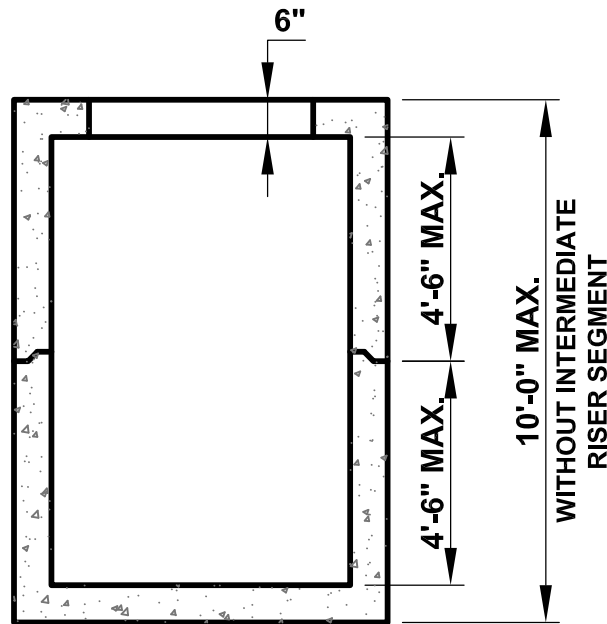

10'-0" MAX.

WITHOUT INTERMEDIATE
RISER SEGMENT

SECTION

STANDARD SPECIFICATIONS

1. MINIMUM CONCRETE COMPRESSIVE STRENGTH: $F'_c = 5,000$ PSI
2. REINFORCEMENT: ASTM A615 GRADE 60, MINIMUM 1" COVER
3. DESIGN & DETAILING CODE: ACI318 (UNLESS OTHERWISE SPECIFIED)
4. AASHTO HS20 LIVE LOAD
5. JOINT SEALANT: 1" BUTYL RUBBER
6. OPENINGS: CAST TO SUIT

DURASTONE

6'x6' PUMP CHAMBER

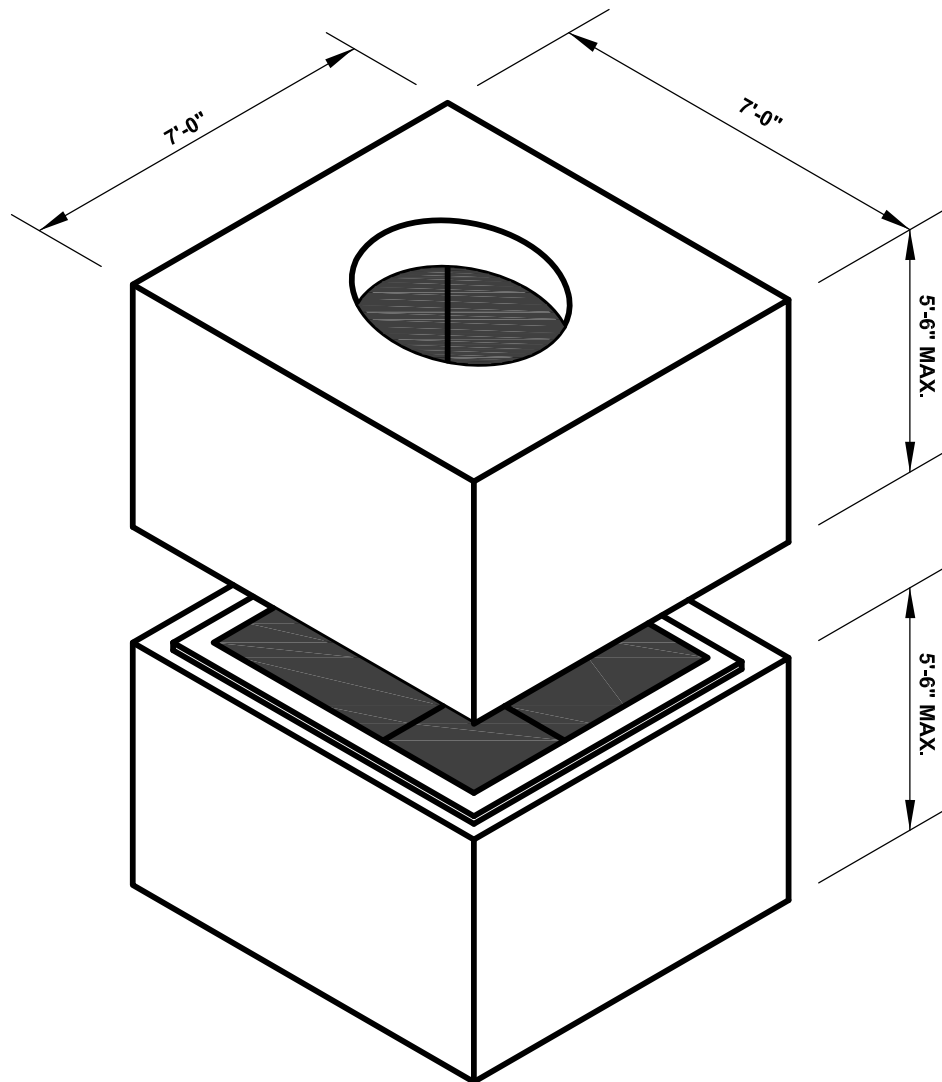

**APPROX. WEIGHT: 26,300 LB
AT MAX. HEIGHT W/O RISER**

INTERMEDIATE RISER SEGMENTS MAY BE
SPECIFIED TO PROVIDE ADDITIONAL DEPTH

150 HIGGINSON AVENUE - LINCOLN, RI 02865 - Phone (401) 723-7100 - Fax (401) 723-6866

NPCA
CERTIFIED PLANT

DURASTONE

150 HIGGINSON AVENUE - LINCOLN, RI 02865 - Phone (401) 723-7100 - Fax (401) 723-6866

6'x6' PUMP CHAMBER

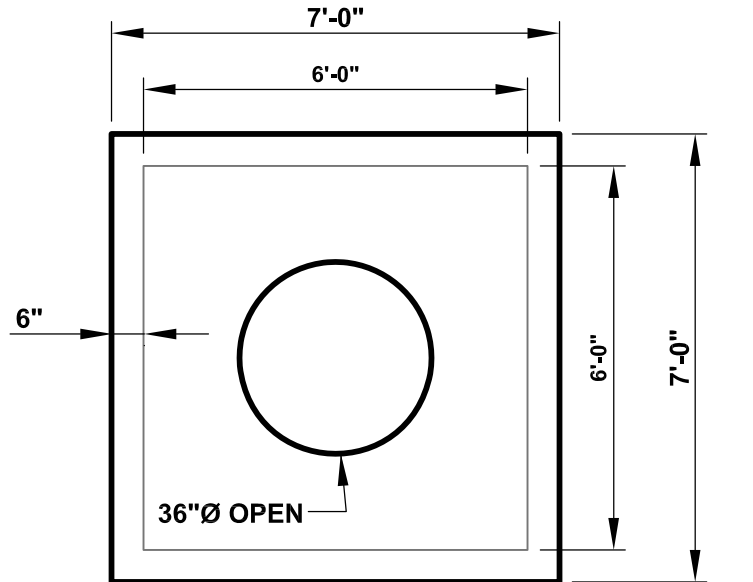

PLAN

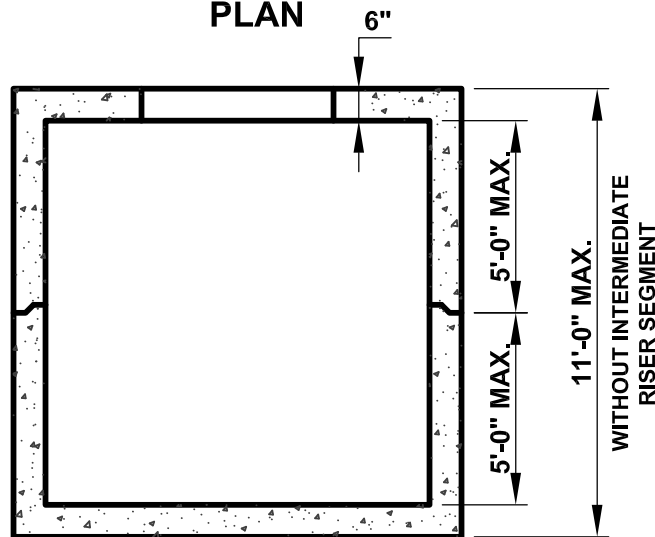

SECTION

STANDARD SPECIFICATIONS

1. MINIMUM CONCRETE COMPRESSIVE STRENGTH: $F'_c = 5,000$ PSI
2. REINFORCEMENT: ASTM A615 GRADE 60, MINIMUM 1" COVER
3. DESIGN & DETAILING CODE: ACI318 (UNLESS OTHERWISE SPECIFIED)
4. AASHTO HS20 LIVE LOAD
5. JOINT SEALANT: 1" BUTYL RUBBER
6. OPENINGS: CAST TO SUIT

DURASTONE

6'x8' PUMP CHAMBER

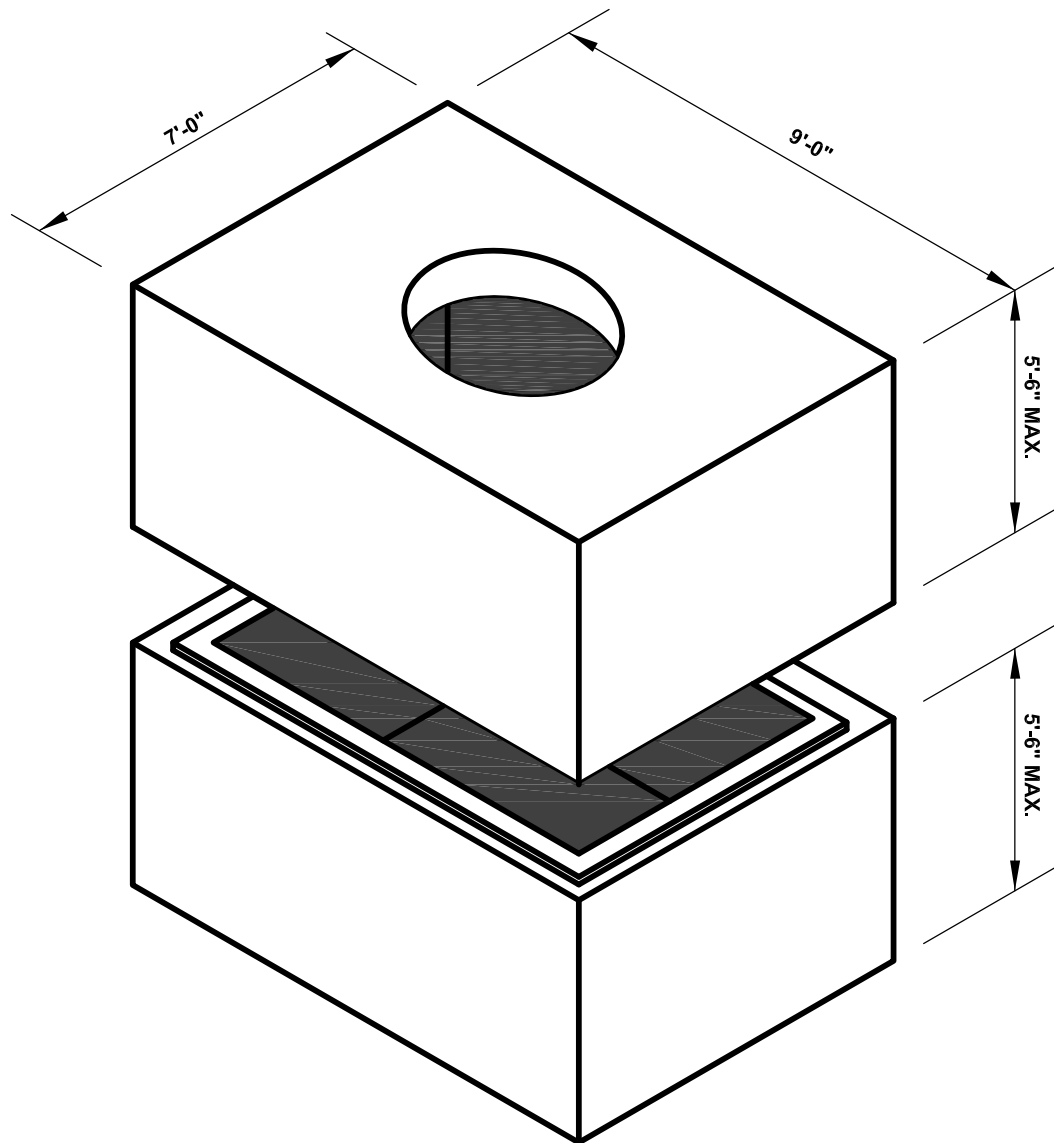

**APPROX. WEIGHT: 31,400 LB
AT MAX. HEIGHT W/O RISER**

INTERMEDIATE RISER SEGMENTS MAY BE
SPECIFIED TO PROVIDE ADDITIONAL DEPTH

150 HIGGINSON AVENUE - LINCOLN, RI 02865 - Phone (401) 723-7100 - Fax (401) 723-6866

NPCA
CERTIFIED PLANT

DURASTONE

150 HIGGINSON AVENUE - LINCOLN, RI 02865 - Phone (401) 723-7100 - Fax (401) 723-6866

6'x8' PUMP CHAMBER

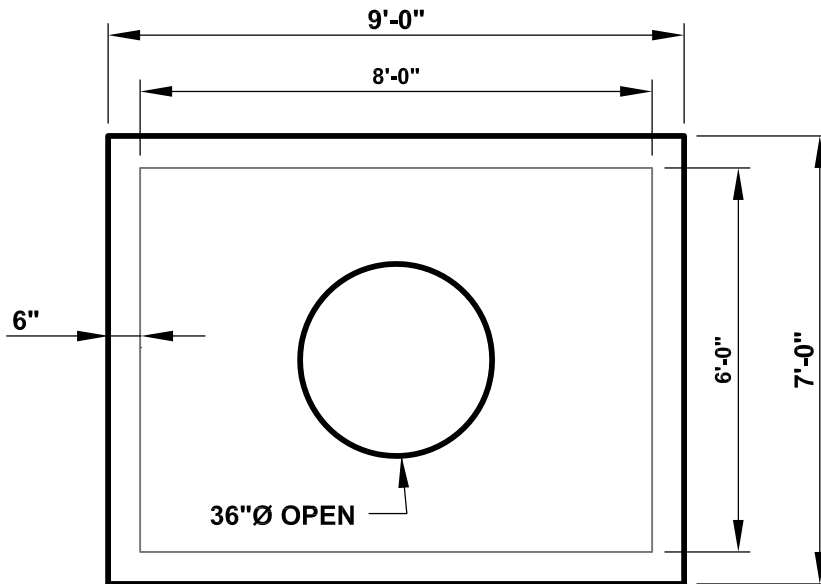

PLAN

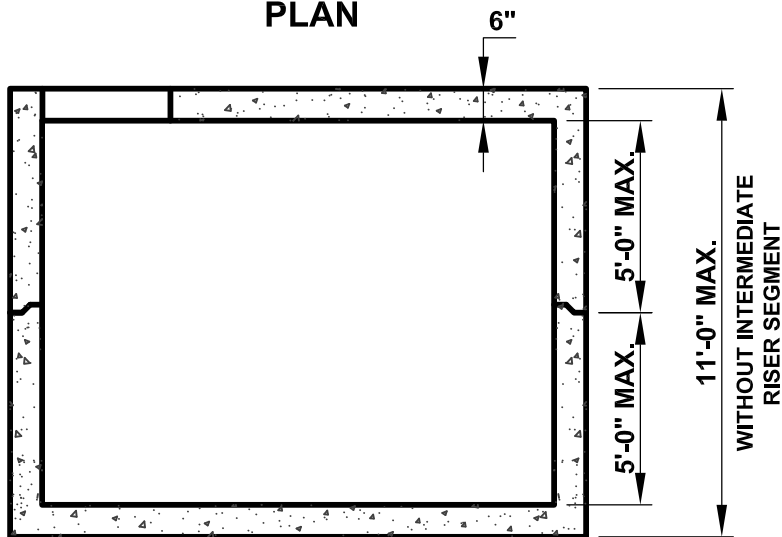

SECTION

STANDARD SPECIFICATIONS

1. MINIMUM CONCRETE COMPRESSIVE STRENGTH: $F'_c = 5,000$ PSI
2. REINFORCEMENT: ASTM A615 GRADE 60, MINIMUM 1" COVER
3. DESIGN & DETAILING CODE: ACI318 (UNLESS OTHERWISE SPECIFIED)
4. AASHTO HS20 LIVE LOAD
5. JOINT SEALANT: 1" BUTYL RUBBER
6. OPENINGS: CAST TO SUIT

DURASTONE

8'x8' PUMP CHAMBER

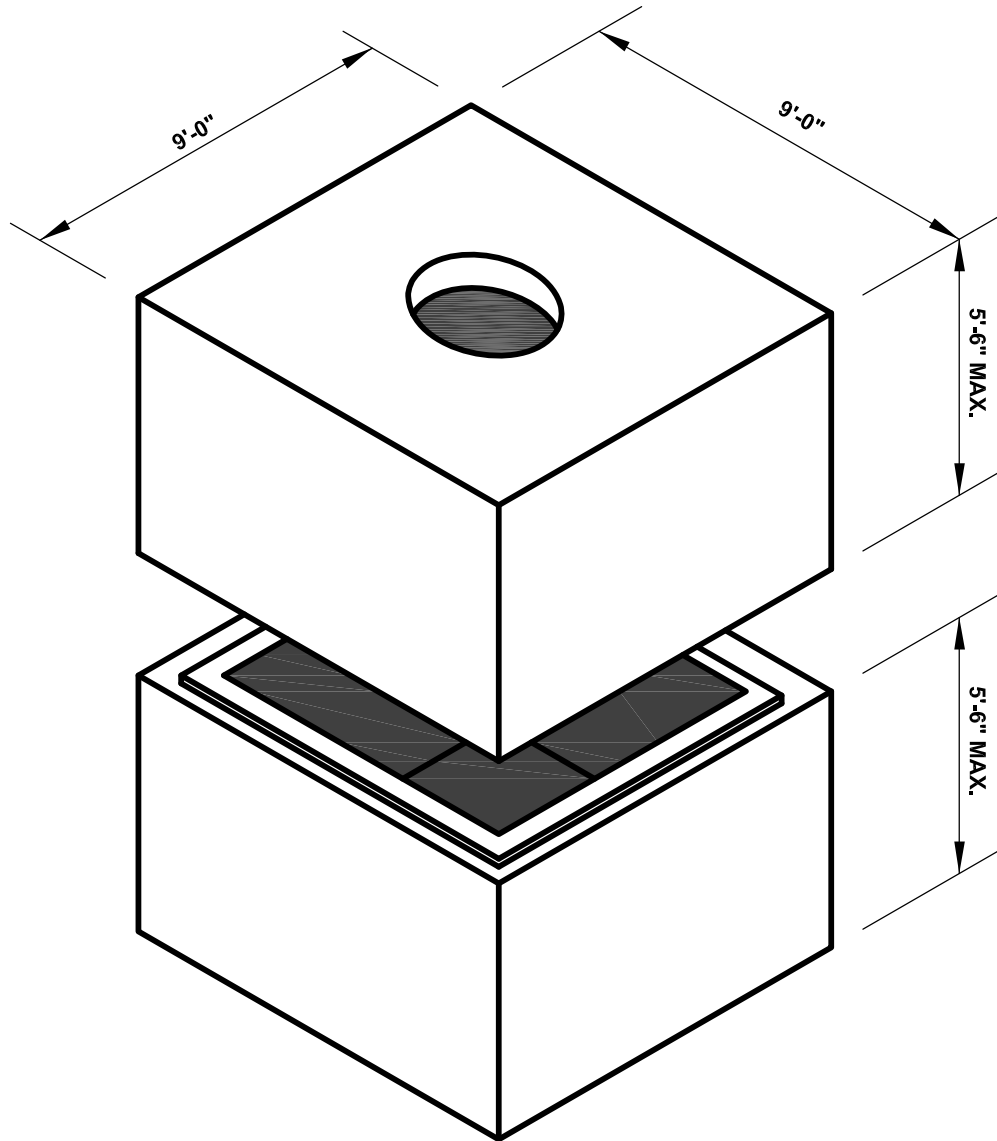

**APPROX. WEIGHT: 39,000 LB
AT MAX. HEIGHT W/O RISER**

INTERMEDIATE RISER SEGMENTS MAY BE
SPECIFIED TO PROVIDE ADDITIONAL DEPTH

150 HIGGINSON AVENUE - LINCOLN, RI 02865 - Phone (401) 723-7100 - Fax (401) 723-6866

NPCA
CERTIFIED PLANT

DURASTONE

150 HIGGINSON AVENUE - LINCOLN, RI 02865 - Phone (401) 723-7100 - Fax (401) 723-6866

8'x8' PUMP CHAMBER

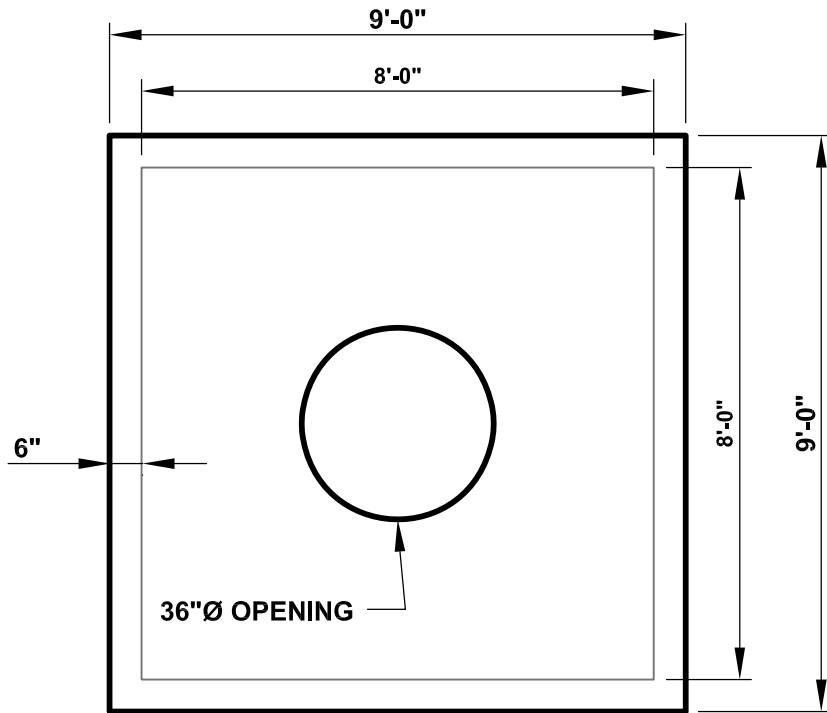

PLAN

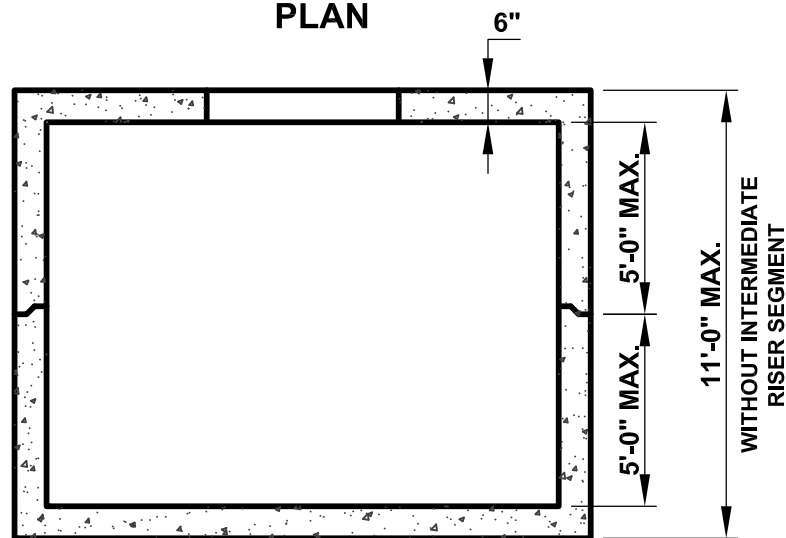

SECTION

STANDARD SPECIFICATIONS

1. MINIMUM CONCRETE COMPRESSIVE STRENGTH: $F'_c = 5,000$ PSI
2. REINFORCEMENT: ASTM A615 GRADE 60, MINIMUM 1" COVER
3. DESIGN & DETAILING CODE: ACI318 (UNLESS OTHERWISE SPECIFIED)
4. AASHTO HL93 LIVE LOAD
5. JOINT SEALANT: 1" BUTYL RUBBER
6. OPENINGS: CAST TO SUIT

DURASTONE

5'x12' PUMP CHAMBER

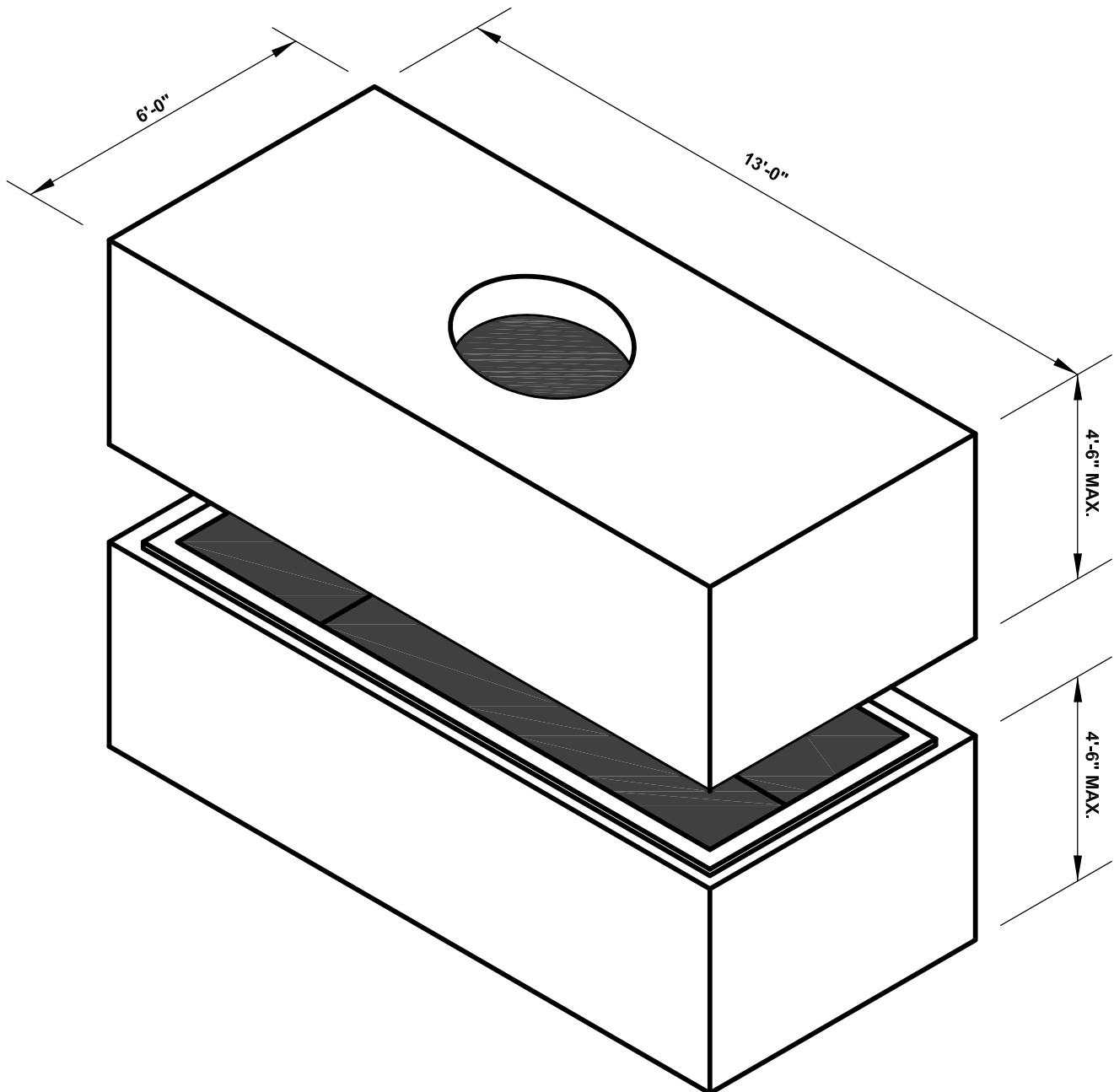

**APPROX. WEIGHT: 32,800 LB
AT MAX. HEIGHT W/O RISER**

INTERMEDIATE RISER SEGMENTS MAY BE
SPECIFIED TO PROVIDE ADDITIONAL DEPTH

150 HIGGINSON AVENUE - LINCOLN, RI 02865 - Phone (401) 723-7100 - Fax (401) 723-6866

NPCA
CERTIFIED PLANT

DURASTONE

150 HIGGINSON AVENUE - LINCOLN, RI 02865 - Phone (401) 723-7100 - Fax (401) 723-6866

5'x12' PUMP CHAMBER

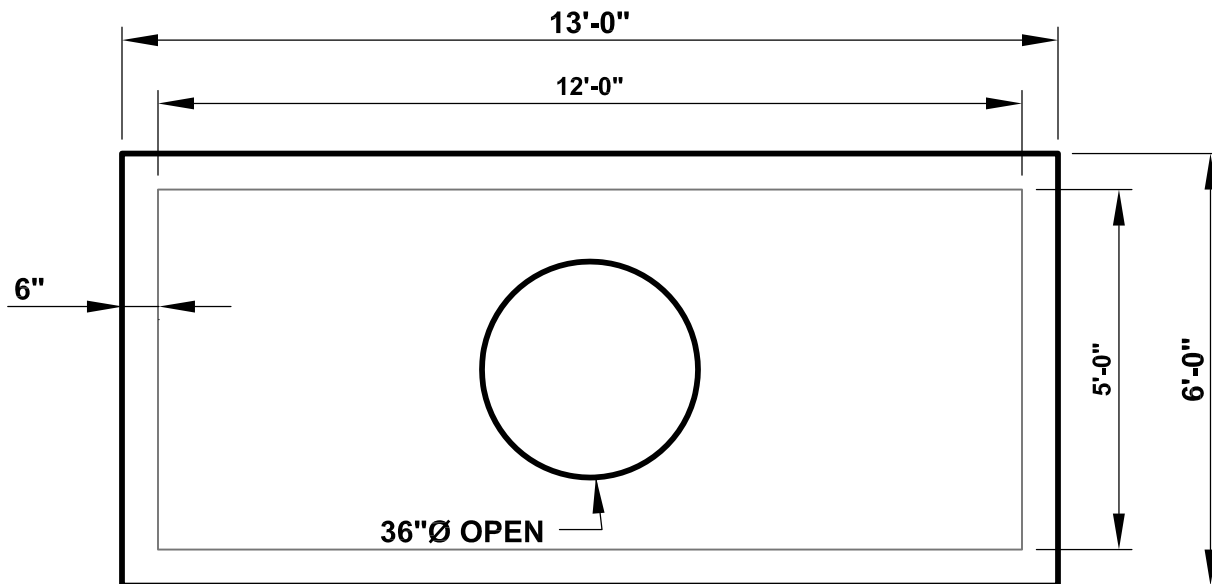

PLAN

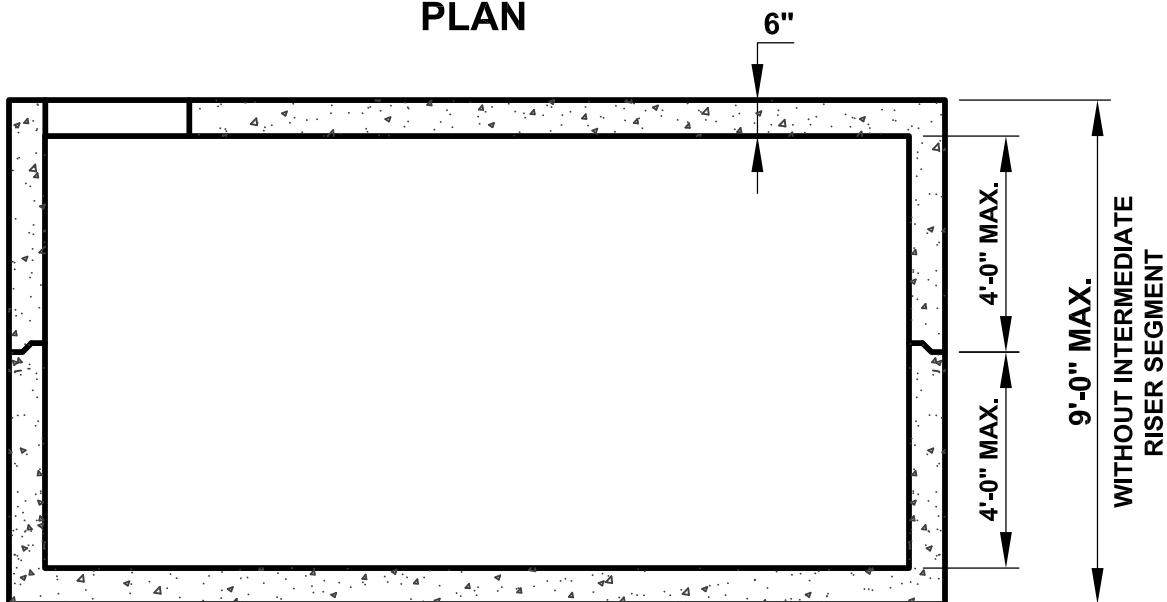

SECTION

STANDARD SPECIFICATIONS

1. MINIMUM CONCRETE COMPRESSIVE STRENGTH: $F'_c = 5,000$ PSI
2. REINFORCEMENT: ASTM A615 GRADE 60, MINIMUM 1" COVER
3. DESIGN & DETAILING CODE: ACI318 (UNLESS OTHERWISE SPECIFIED)
4. AASHTO HS20 LIVE LOAD
5. JOINT SEALANT: 1" BUTYL RUBBER
6. OPENINGS: CAST TO SUIT

DURASTONE

6'x16' PUMP CHAMBER

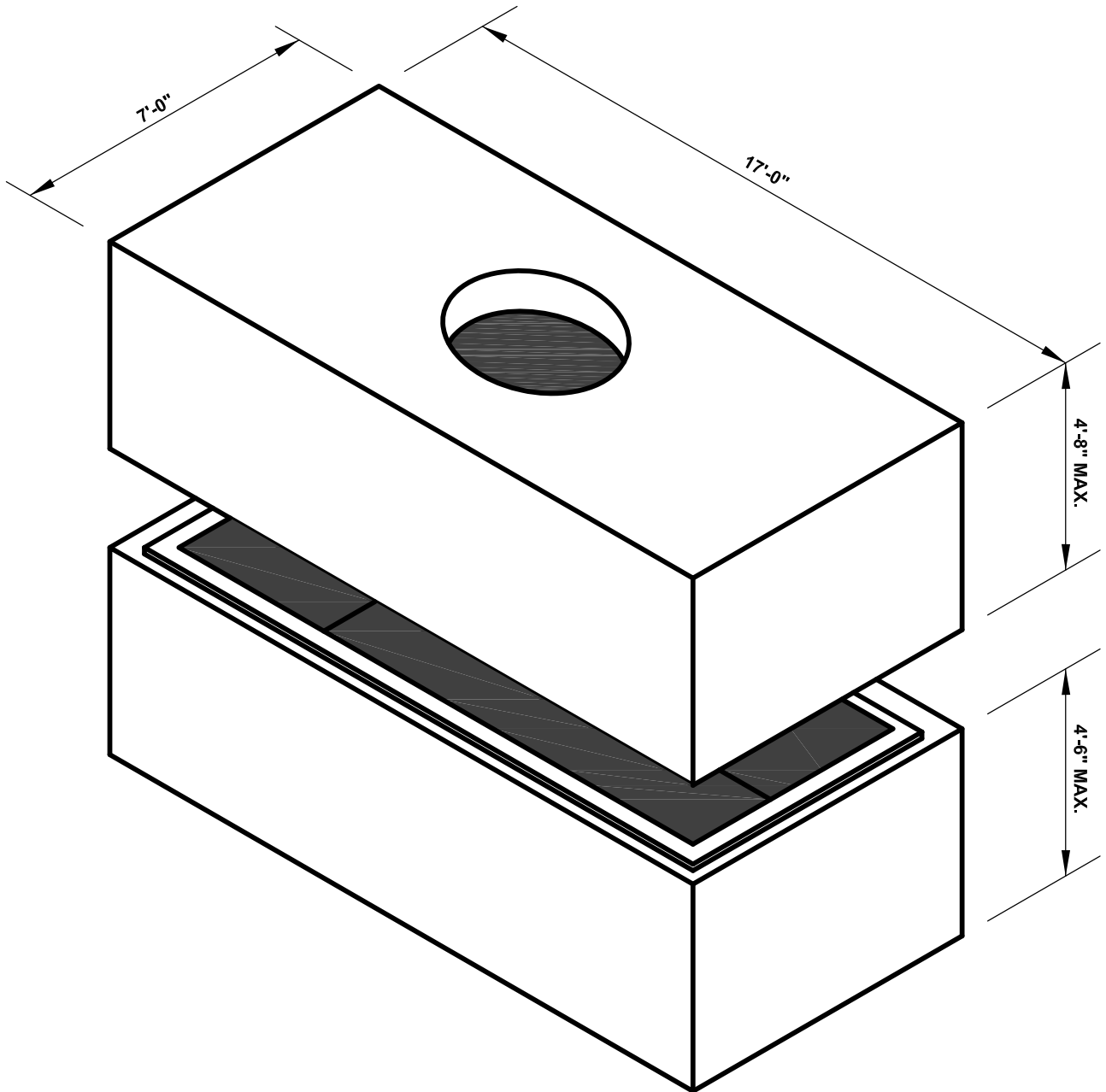

**APPROX. WEIGHT: 48,000 LB
AT MAX. HEIGHT W/O RISER**

INTERMEDIATE RISER SEGMENTS MAY BE
SPECIFIED TO PROVIDE ADDITIONAL DEPTH

150 HIGGINSON AVENUE - LINCOLN, RI 02865 - Phone (401) 723-7100 - Fax (401) 723-6866

NPCA
CERTIFIED PLANT

DURASTONE

150 HIGGINSON AVENUE - LINCOLN, RI 02865 - Phone (401) 723-7100 - Fax (401) 723-6866

6'x16' PUMP CHAMBER

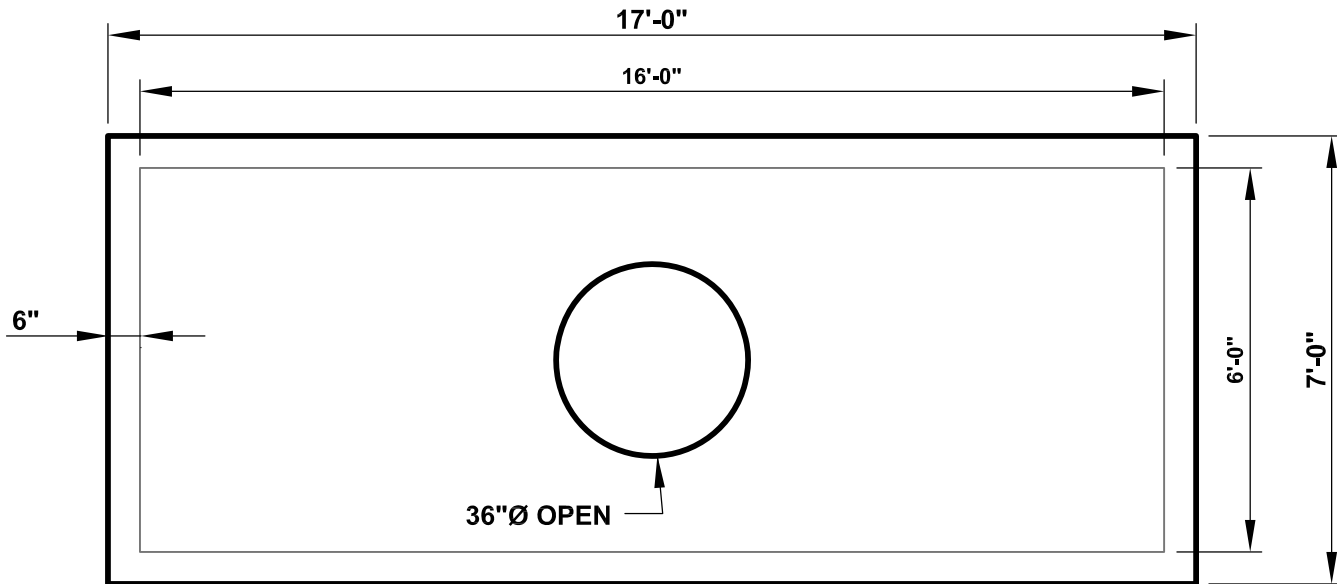

PLAN

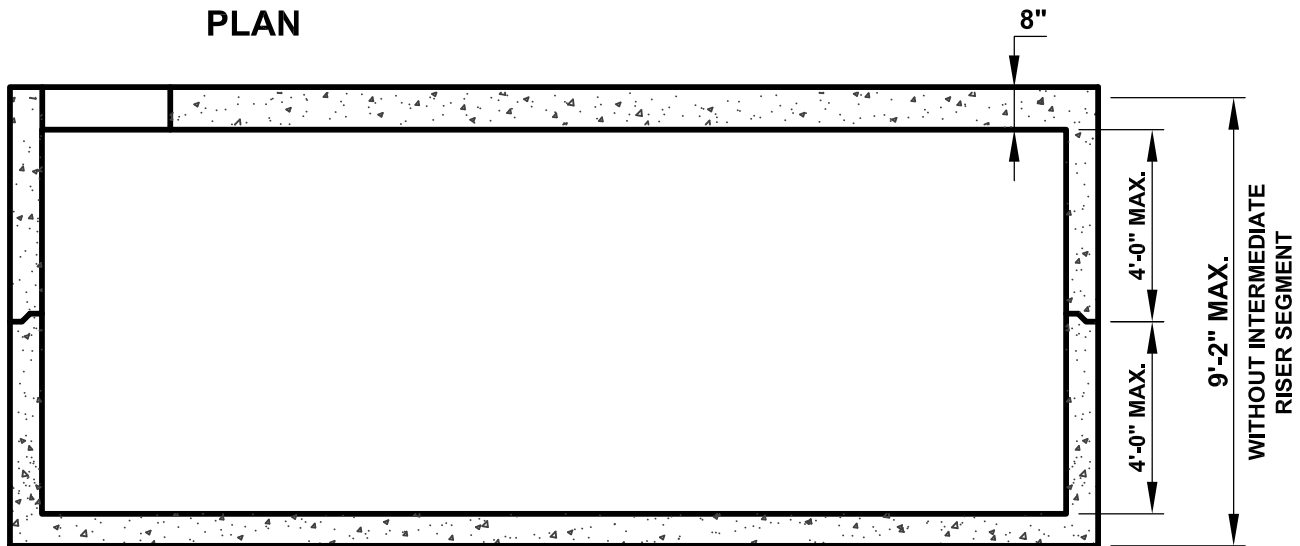

SECTION

STANDARD SPECIFICATIONS

1. MINIMUM CONCRETE COMPRESSIVE STRENGTH: $F'_c = 5,000$ PSI
2. REINFORCEMENT: ASTM A615 GRADE 60, MINIMUM 1" COVER
3. DESIGN & DETAILING CODE: ACI318 (UNLESS OTHERWISE SPECIFIED)
4. AASHTO HS20 LIVE LOAD
5. JOINT SEALANT: 1" BUTYL RUBBER
6. OPENINGS: CAST TO SUIT

DURASTONE

9'x16' PUMP CHAMBER

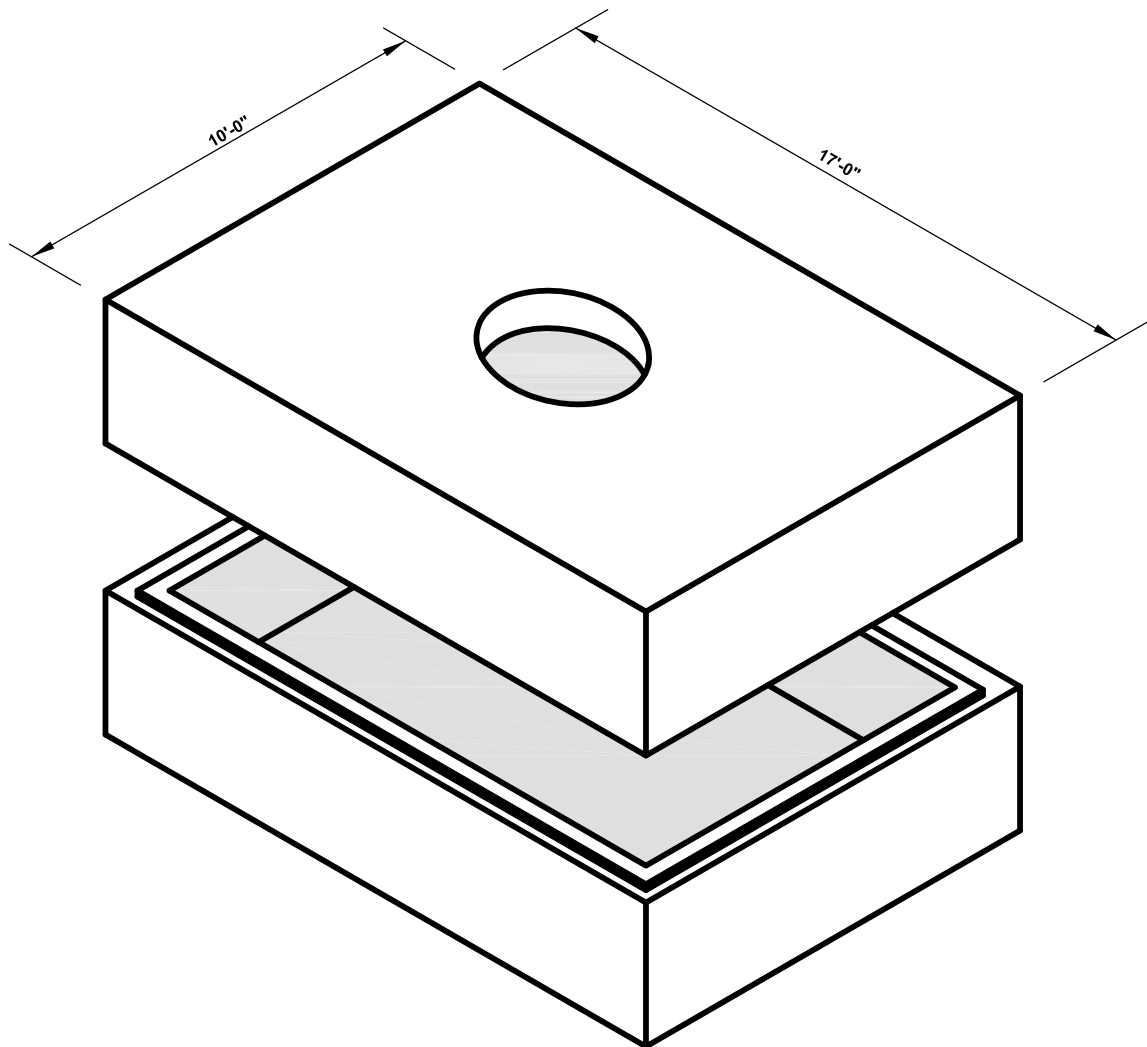

150 HIGGINSON AVENUE - LINCOLN, RI 02865 - Phone (401) 723-7100 - Fax (401) 723-6866

NPCA
CERTIFIED PLANT

DURASTONE

150 HIGGINSON AVENUE - LINCOLN, RI 02865 - Phone (401) 723-7100 - Fax (401) 723-6866

9'x16' PUMP CHAMBER

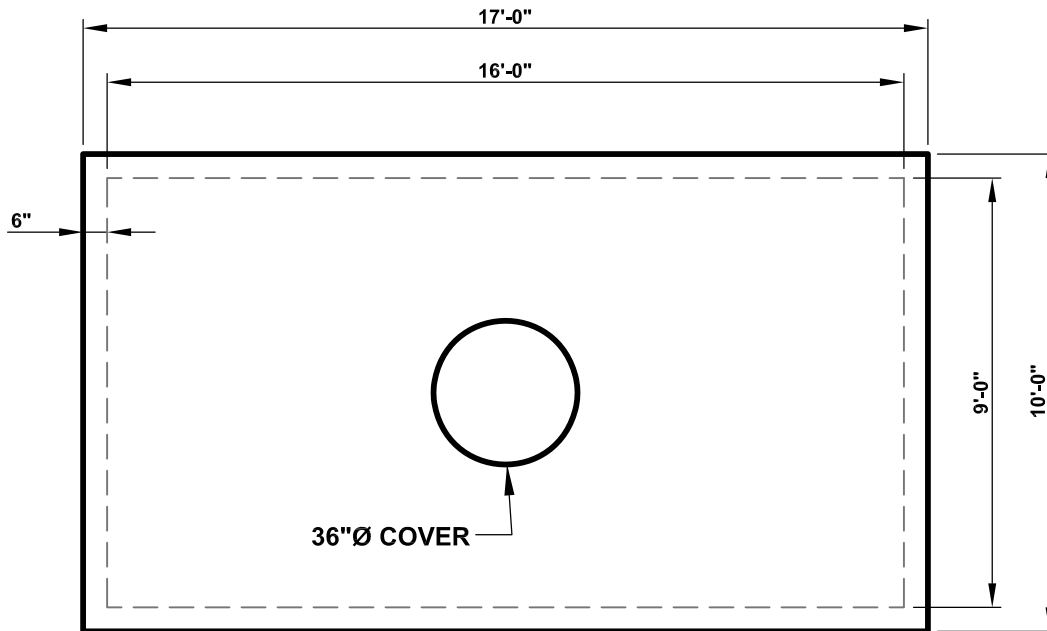

PLAN

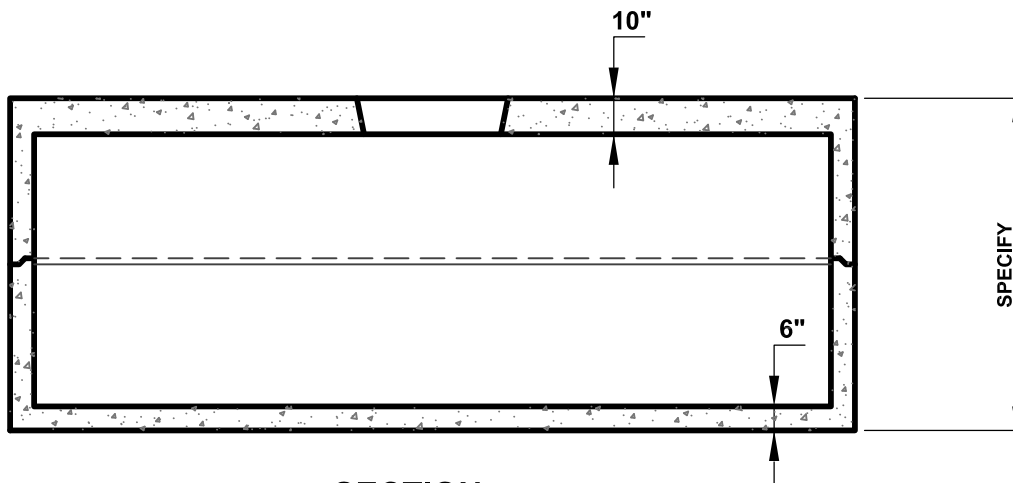

SECTION

STANDARD SPECIFICATIONS

1. MINIMUM CONCRETE COMPRESSIVE STRENGTH: $F'_c = 5,000$ PSI
2. REINFORCEMENT: ASTM A615 GRADE 60, MINIMUM 1" COVER
3. DESIGN & DETAILING CODE: ACI318 (UNLESS OTHERWISE SPECIFIED)
4. AASHTO HL93 LIVE LOAD
5. JOINT SEALANT: 1" BUTYL RUBBER
6. OPENINGS: CAST TO SUIT