

DURASTONE

RETAINING WALL SYSTEM

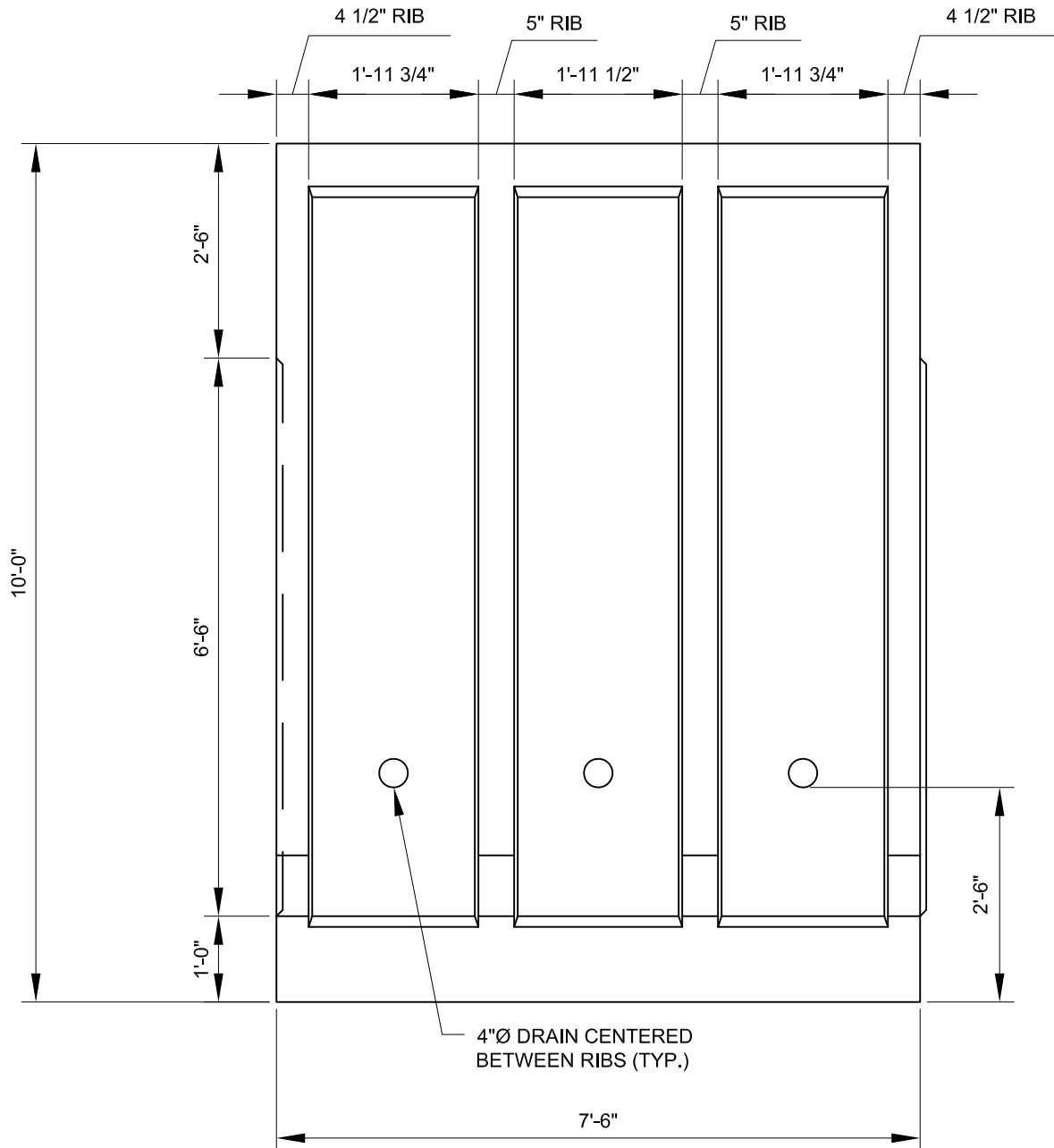

ELEVATION

APPROX. WEIGHT: 12,100 LB

150 HIGGINSON AVENUE - LINCOLN, RI 02865 - Phone (401) 723-7100 - Fax (401) 723-6866

NPCA
CERTIFIED PLANT

DURASTONE

150 HIGGINSON AVENUE - LINCOLN, RI 02865 - Phone (401) 723-7100 - Fax (401) 723-6866

RETAINING WALL SYSTEM

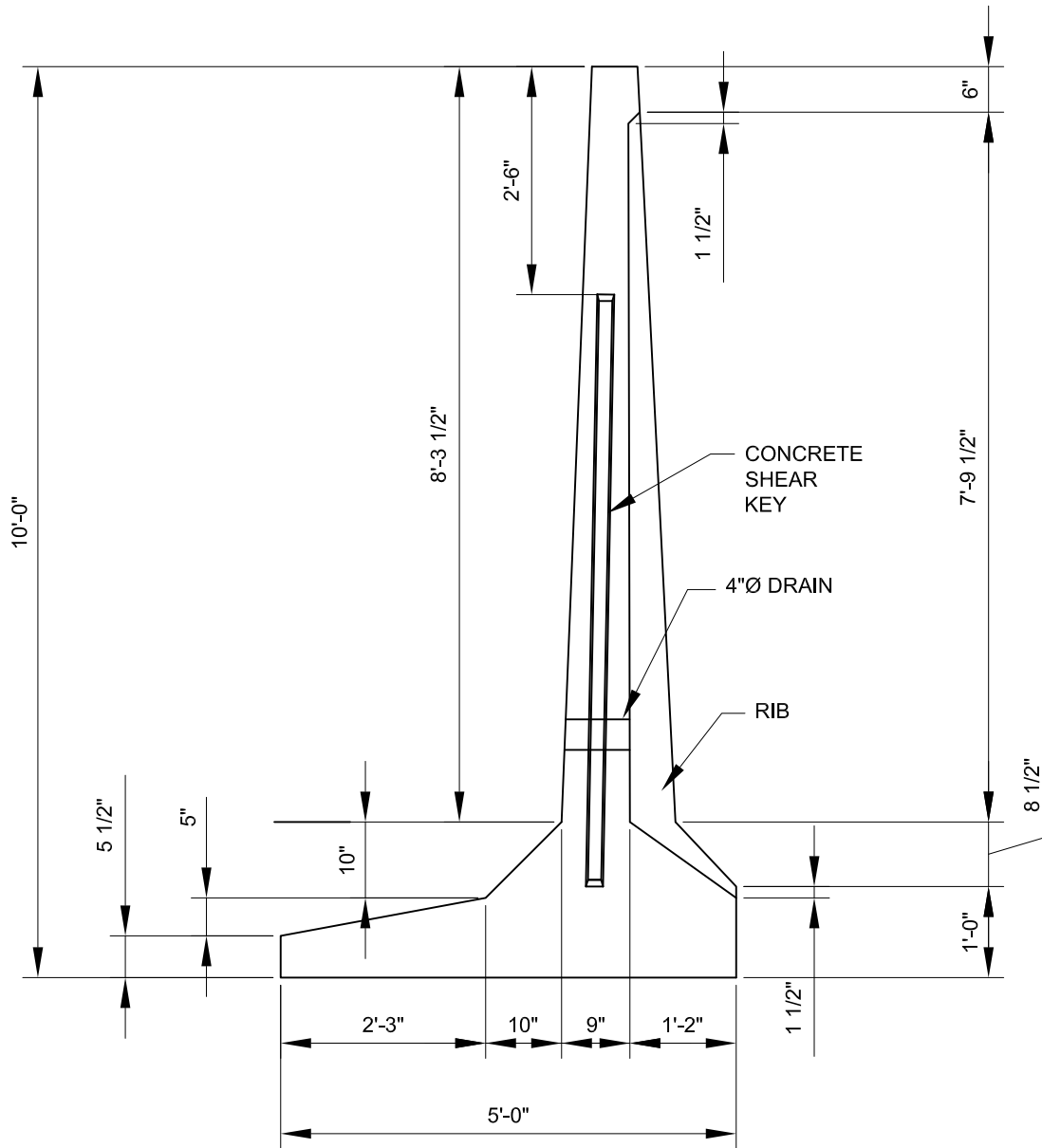

SECTION

STANDARD SPECIFICATIONS

1. MINIMUM CONCRETE COMPRESSIVE STRENGTH: $f'_c = 5,000$ PSI
2. REINFORCEMENT: ASTM A615 GRADE 60, MINIMUM 1" COVER
3. DESIGN & DETAILING CODE: ACI318 (UNLESS OTHERWISE SPECIFIED)

DURASTONE

ARCHITECTURAL BLOCK

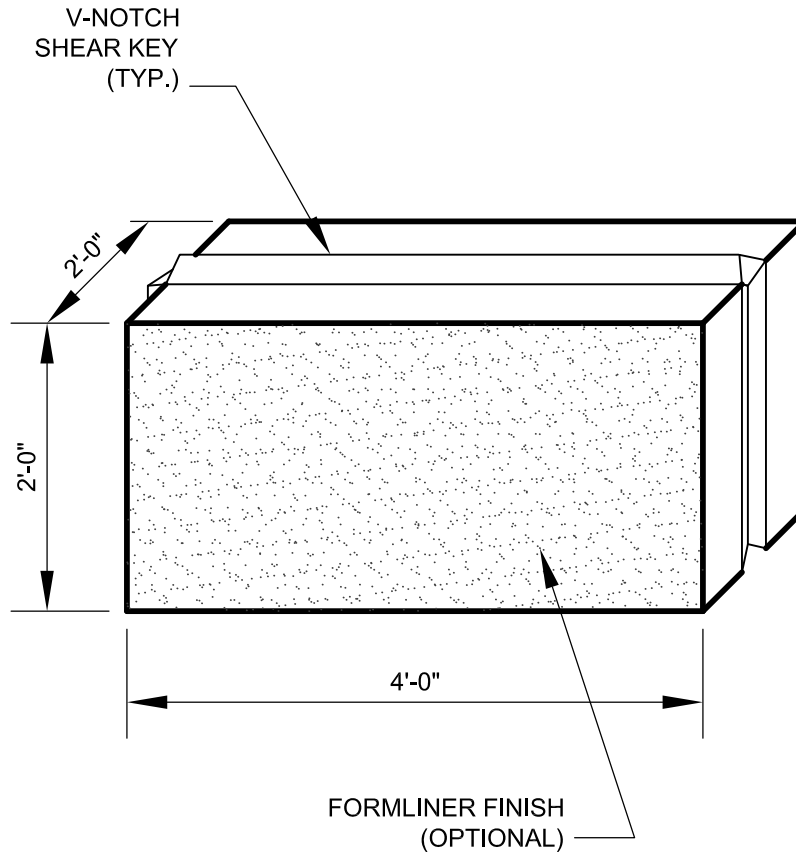

APPROX. WEIGHTS:

4'x2'x2' BLOCK: 2,400#

STANDARD SPECIFICATIONS

1. MINIMUM CONCRETE COMPRESSIVE STRENGTH: $f'_c = 4,000$ PSI
2. OPTIONAL FORMLINER FINISH (SPECIFY)
3. WALL DESIGN BY OTHERS

150 HIGGINSON AVENUE - LINCOLN, RI 02865 - Phone (401) 723-7100 - Fax (401) 723-6866

NPCA
CERTIFIED PLANT

DURASTONE

ARCHITECTURAL BLOCK

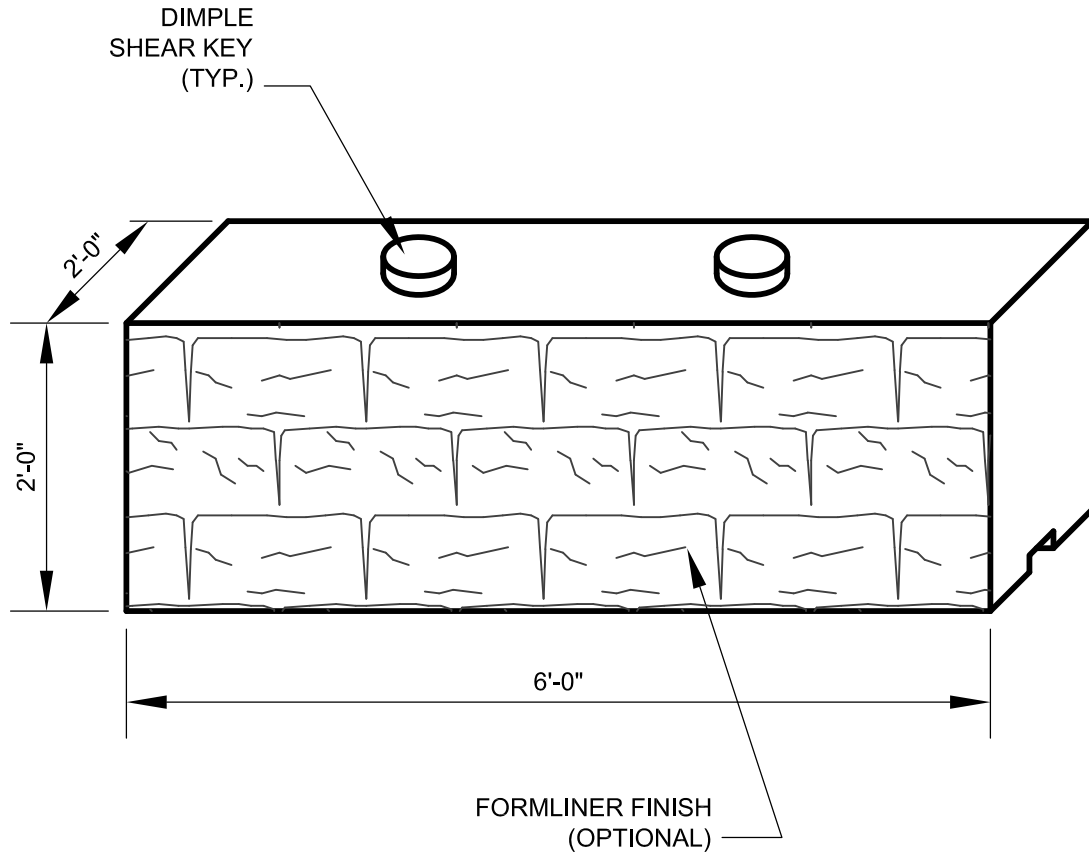

APPROX. WEIGHTS:

6'x2'x2' BLOCK: 3,600#

STANDARD SPECIFICATIONS

1. MINIMUM CONCRETE COMPRESSIVE STRENGTH: $f'_c = 4,000$ PSI
2. OPTIONAL FORMLINER FINISH (SPECIFY)
3. WALL DESIGN BY OTHERS

150 HIGGINSON AVENUE - LINCOLN, RI 02865 - Phone (401) 723-7100 - Fax (401) 723-6866

NPCA
CERTIFIED PLANT